

E. ENERGY-EFFICIENT MECHANICAL AND VENTILATION SYSTEMS

1. General

- a. Heating, ventilation, and air conditioning (HVAC) systems are typically responsible for 35%–50% of the energy consumed in buildings. By using the "whole-building" approach — looking at how all the building's design elements work together — the design team can factor in energy-saving choices that reduce heating and cooling loads and downsize the HVAC system required.
- b. HVAC systems have a significant effect on the health, comfort, productivity, and performance of occupants. Most of these issues are directly or indirectly linked to HVAC system design and operation, and should be maximized by improved mechanical and ventilation systems.
- c. Consider the HVAC design that relates all the interrelated building systems while addressing indoor air quality, energy consumption, and environmental benefit. To optimize the design to receive full benefits, the mechanical system designer and architect should address these issues early in the programming/schematic design phase and continue to assess energy consumption throughout the remaining design process. It is also important that the Owner implement appropriate levels of commissioning and routine preventative maintenance programs on mechanical systems.
- d. Establish mechanical equipment location and space requirements and their service clearances for commissioning proper equipment maintenance and replacement.

2. Energy Analysis

- a. To optimize the selection of efficient, cost-effective mechanical and ventilation systems, an energy analysis should be performed early in the process, during the schematic design phase. Several available computer programs can provide building simulations on an hourly basis to predict the energy behavior of the building's structure, air conditioning system, electrical, and central equipment plant.
- b. An energy analysis considers the building's key components — the building walls and roof, insulation, glazing, the lighting and daylighting systems, as well as the HVAC systems and equipment. The analysis program can simultaneously assess and predict the results of choices associated with each component. For buildings in the design phase, computer models are generally useful for comparing alternatives and predicting trends.
- c. Energy analysis computer programs that simulate hourly performance should include a companion economic simulation to calculate energy costs based on computed energy use. This model can estimate monthly and annual energy usage and costs. Some models allow the user to input estimated capital equipment and operating costs so that the life-cycle economics of the design can be evaluated and compared.
 1. Prior to starting work on the design, establish an "energy budget" for the project that is lower than the maximum required for the facility.
 2. Develop a clear understanding of balancing initial cost versus life-cycle cost and point out the long-term advantages of investing in more energy-efficient approaches.

3. When evaluating life-cycle costs, take into account:
 - a. the initial cost of equipment;
 - b. the anticipated maintenance expenses;
 - c. the projected labor costs with escalation rates;
 - d. replacement costs;
 - e. life expectancy of equipment.
4. Incorporate the evaluation of different fuel and energy source options over the life-cycle period. There are many alternative designs that can be used to supply air conditioning to a building. The final selection of an air conditioning system should be primarily based on the option with the least life cycle cost. Other secondary factors like space requirements, degree of control, maintenance factors, flexibility, need for individual zoning, acoustics, reliability, and off-hour operation should also be considered.
5. Identify and evaluate appropriate HVAC systems based on the building type, new or existing, and its use.
6. The most efficient systems minimize the energy required during operation by matching their air supply to the load without adding a penalty for reheat. These include: variable air volume for interior air supply with perimeter radiation for heating, interior variable air volume with perimeter constant volume, and interior variable air volume central air handling supplying air to variable air volume terminal units equipped with re-heating coils.
7. Consider variable air volume (VAV) systems with different types of terminal units, including:
 - a. Variable air volume (VAV) with reheat coil;
 - b. Series fan-powered VAV terminal unit; and
 - c. Parallel fan-powered VAV terminal unit.
8. Evaluate the HVAC system and design criteria in accordance with applicable North Carolina Building codes and ASHRAE standards to:
 - a. Provide adequate ventilation for the building occupants and building intended function; and
 - b. Facilitate maintainability and cleanability of the HVAC system.
9. All potentially viable (at least two) HVAC systems should be identified and life cycle cost analyses performed on them. There are many options available with central plant-hydronic and central plant air delivery systems.

10. Consider energy use and operating expenditures at the outset of the design process, so energy and resource-efficient strategies can be integrated at the lowest possible cost.
11. Optimize the mechanical system as a complete entity to allow for interactions between system components.
12. A report should be generated containing a life cycle cost analysis of HVAC systems with justification of recommended HVAC systems at schematic and design development phases of the project. If major changes in the building design are made, revised life cycle analyses should be performed at the construction document phase of the project.
13. A report and verification of the energy analysis is required at the eleven (11) month warranty inspection.

3. Cooling Systems

- a. Consider cooling systems that match the profile and building loads.
- b. Evaluate various cooling equipment sizes and models to select the unit that best matches the demand requirements. To accomplish this, use an hourly computer simulation tool to generate energy consumption profiles and the incidence of coincidental peak cooling loads. Select equipment that achieves a high efficiency at the predominant load but also remains efficient over the range of operating conditions.

Refrigeration Units

The Coefficient of Performance (COP) of refrigeration systems is the ratio of the net heat removal by the evaporator to the total energy input to the compressor.

Type	Size (Tons)	Condensing	Minimum COP	Best COP	Average COP
A/C Package Units	< 5	Air	2.93	4.70	3.50
		Water	2.64	5.30	3.00
	> 5	Air	2.49	4.70	3.50
		Water	2.78	5.3	3.14
Chillers					
Centrifugal:	100-2,000	Water	5.41	7.33	6.40
Screw:	100-750	Air	2.40	3.06	2.80
Centrifugal and Screw:	< 250	Water	4.40	5.90	4.52
	> 250	Water	4.40	7.33	5.87
Reciprocating:	50-250	Air	2.55	3.00	2.78
	10-1,500	Water	3.64	4.20	3.92
Absorption:					
Direct-Fired					
Single-Stage		Water	0.48	0.67	0.58
Two-Stage		Water		1.02	
Indirect-Fired					
Single-Stage		Water	0.68	0.71	0.70
Two-Stage		Water		1.14	

Source: Developed by Padia Consulting from manufacturer's literature

- c. Evaluate an efficient arrangement of chiller(s), options for ΔT and subsequently its impact, chilled water ΔT , chilled water flow, and kW input/ton at full and part-load. Consider variable primary flow for the chiller to eliminate the use of a secondary chilled water pump and still have the advantage of a variable flow system.

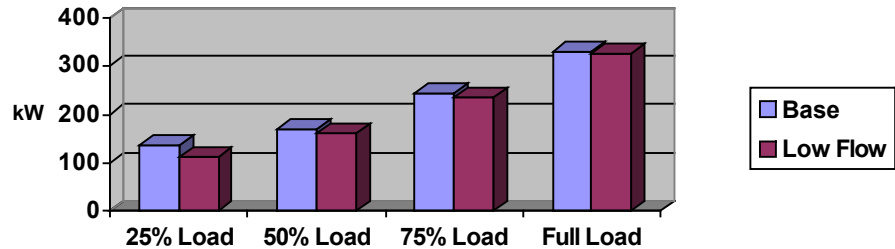

This graph illustrates chilled-water-system performance at part-load. Typically, higher chilled water ΔT with a low flow system results in lower kW input.

- d. Evaluate type of cooling tower, condenser water ΔT , condenser water flow, condenser water temperature control and control of the cooling tower fan(s).
- e. Analyze chiller plant efficiency as a whole considering:
1. actual weather data;
 2. building load characteristics/profile;
 3. number of chillers with number of compressors;
 4. operational hours;
 5. economizer capabilities;
 6. auxiliary energy draws (e.g., pumps, fans, basin heaters, etc.); and
 7. energy source
- f. Consider the use of air side economizer and/or waterside economizer to provide free cooling.
- g. Use nighttime ventilation strategies to cool interior mass and flush out stale air prior to morning occupancy. This purging cycle can be effective in areas with low nighttime temperatures. Consider humidity levels inside building if this strategy is utilized.
- h. Use environmentally friendly refrigerant alternatives. Also, as an alternative to chlorofluorocarbons (CFC's) refrigerants, the design team should consider absorption refrigeration units which are CFC free and use water as the refrigerant and lithium bromide as the absorbent. This option can also be an economical way of cooling and heating large buildings. These compact, high efficiency units are available in models providing from 40 to 1500 tons of cooling and operate on natural gas, propane, oil, exhaust heat or steam. Because they avoid the increasingly expensive use of electricity for air conditioning, these units can cut cooling and heating costs substantially.
- i. Absorption cooling systems allow changing of the energy source from electricity to gas and can reduce energy costs. Direct-fired gas equipment can also be selected to provide hot water for building needs in addition to chilled water. This type of system is ideal for a solar thermal energy application.

- j. Consider thermal (ice) storage in situations where peak load avoidance is critical. Thermal storage is not necessarily an energy efficiency measure, but a cost-saving technique which takes advantage of off-peak utility rate schedules where applicable. Electric utilities may have promotions for thermal storage by offering an incentive for power usage that can be displaced from peak to off-peak time. Making of ice should be considered during non-occupied hour.
- k. For cooling, consider the use of Desiccant Dehumidification Technology to resolve problems arising from mold and mildew.

The diagram on the following page illustrates the schematic design of ice thermal storage for the Wake County Human Services Building on Swinburne Street in Raleigh, North Carolina. Ice thermal storage should be considered when electric demand changes are high and cost of electricity is significantly lower during off hours.

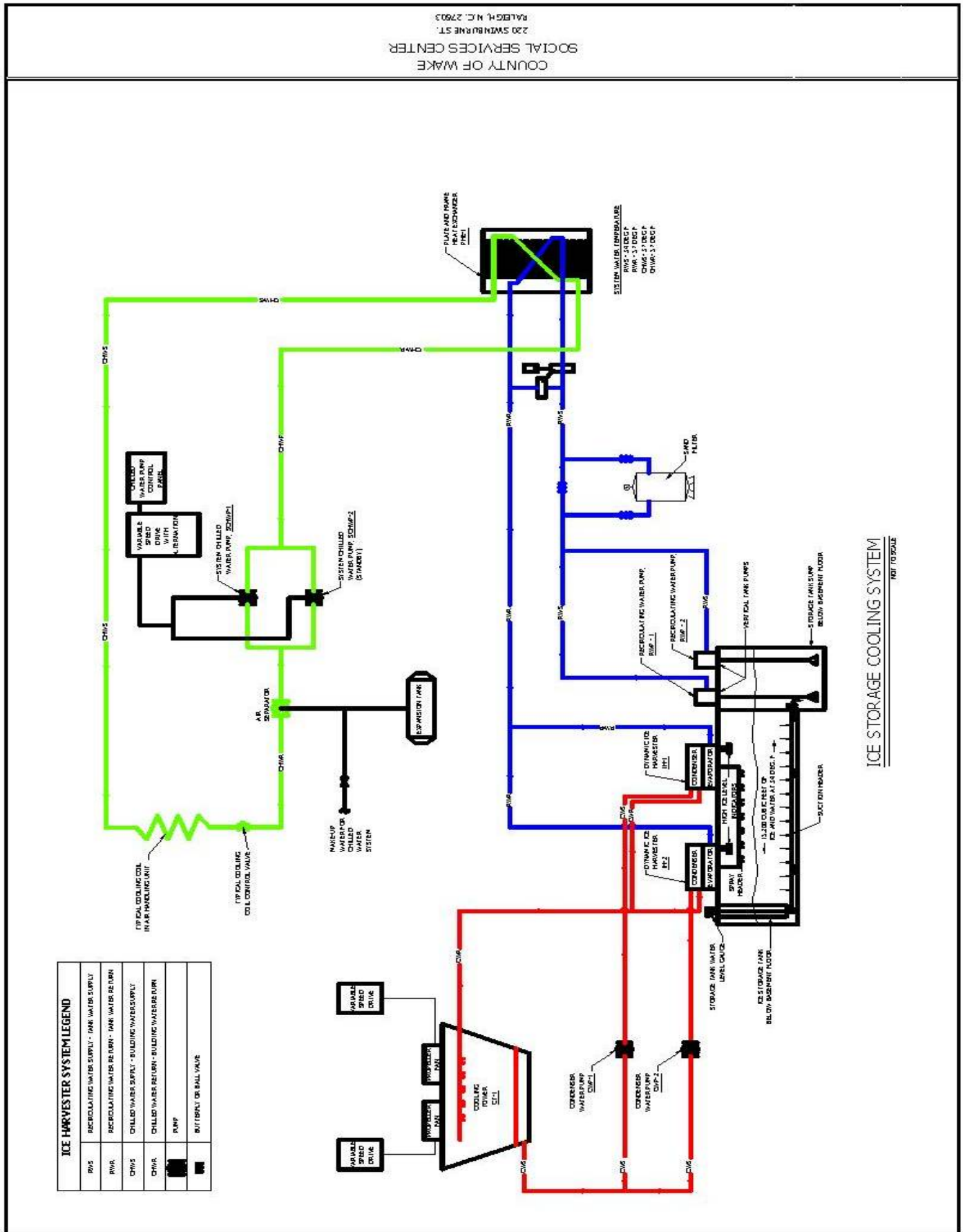

4. Boilers

- a. When considering centralized systems, choose the most efficient heating for the particular need.
- b. Evaluate type and arrangement of boiler(s), heating ΔT , hot water flow, and boiler efficiency.
- c. Consider condensing boilers. They are typically 10% to 15% more efficient than conventional boilers.

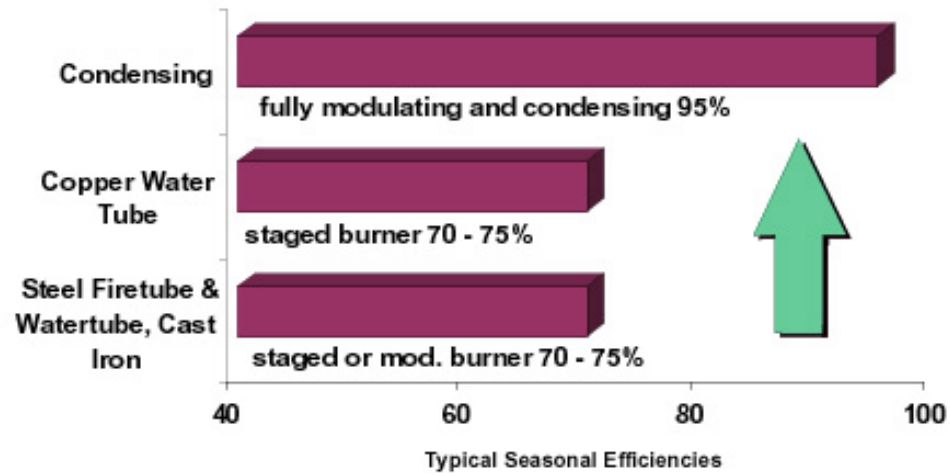

On an average, fully-modulating and condensing boilers typically result in 20-25% higher efficiency when compared with staged or modulating non-condensing boilers.

- d. Consider multiple, modular boilers that are more efficient at partial load.
- e. Employ draft control devices that reduce off-cycle losses.
- f. Design water reset control that is keyed to outside air temperature.
- g. Incorporate burner flame controls.
- h. For small renovation projects, install DDC control systems to control night and weekend set-back.

5. Ventilation and Indoor Air Quality Strategies

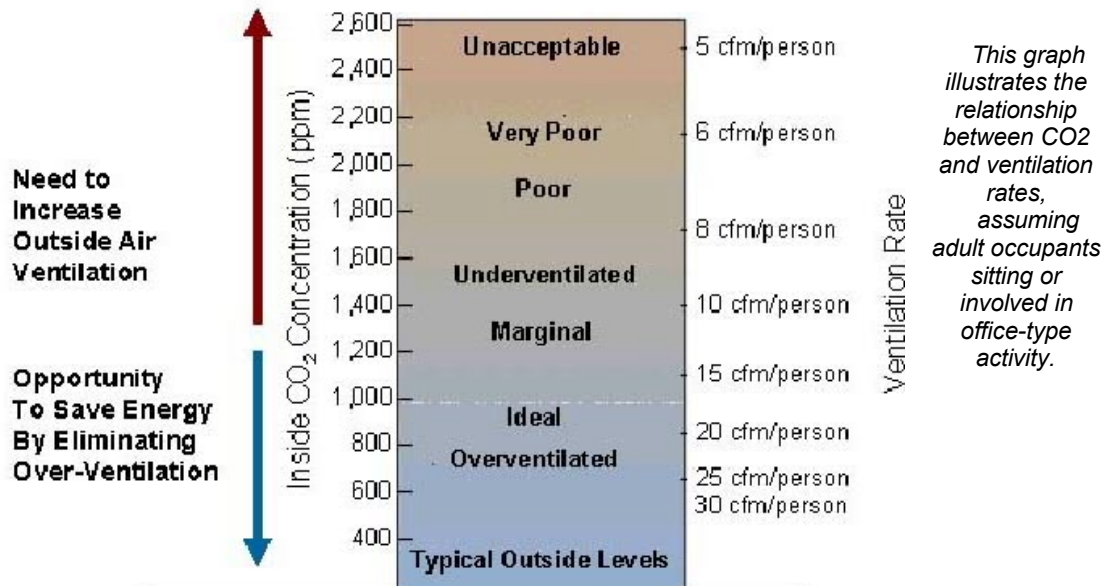

- Use current building codes and ASHRAE Standards, which address the criteria necessary to meet ventilation and indoor air quality requirements. The outside air requirements for proper ventilation of an occupied facility are considerable and have a substantial impact on HVAC system energy consumption and operating costs. The strategy employed to achieve proper ventilation should be carefully considered.
- Consider a dedicated ventilation system such that the quantity of air can be regulated and measured, providing a greater certainty that proper ventilation and humidity is maintained. Such a dedicated system can also improve overall energy efficiency.
- Consider the use of a heat recovery system, like an air-to-air heat exchanger, that will transfer the heat between air supplied to and air exhausted from the building.
- Separate and ventilate highly polluting spaces. Provide separate exhaust from kitchens, toilets, custodial closets, chemical storage rooms, dedicated copy rooms, and designated smoking areas with no recirculation through the HVAC system.
- Evaluate the use of an outdoor air economizer cycle that will allow up to 100% outdoor air to be introduced into the distribution system to provide space cooling.
- Locate outdoor air intakes a minimum of 7 feet vertically and 25 feet horizontally from polluted and/or overheated exhaust (e.g., cooling towers, loading docks, fume hoods, and chemical storage areas). Consider other potential sources of contaminants, such as lawn maintenance. Separate vehicle traffic and parking a minimum of 50 feet from outdoor air inlets or spaces employing natural ventilation strategies. Create landscaping buffers between high traffic areas and building intakes or natural ventilation openings.
- Locate exhaust outlets at a minimum of 10 feet above ground level and away from doors, occupied areas, and operable windows. The preferred location for exhaust outlets is at roof level projecting upward or horizontally away from outdoor intakes.

6. Air Distribution Systems

- a. Design an air distribution system that is energy efficient and protects against poor indoor air quality. Use ducted returns.
- b. Where individual room control is desired or diverse loads are present, employ variable air volume systems (versus constant air systems) to capitalize on reduced fan loads during times of reduced demand.
- c. Use constant volume systems when the load is uniform and predictable (e.g., kitchen).
- d. If a particular mechanical system serves more than one space, ensure that each space served has the same orientation and fulfills similar functions. Consider independent mechanical rooms and systems on separate floors to reduce ductwork and enhance the balance of air delivered.
- e. Consider a design that supplies air at lower temperatures to reduce airflow requirements and fan energy.
- f. Provide proper air distribution to deliver conditioned air to the occupant's work areas. The selection and location of diffusers can save energy and improve operation of the HVAC system control. Select diffusers with high induction ratios, low pressure drop, and good partial-flow performance. Locate diffusers for proper airflow, not on the basis of a simplistic pattern. Coordinate the layout with furniture and partitions.
- g. Minimize long duct runs and unnecessary turns and curves to keep static pressure losses to a minimum and, in turn, reduce the fan's energy consumption. Avoid elbows directly at AHU's.
- h. Specify ductwork that has smooth interior surfaces and transitions to minimize the collection of microbial growth. Design ductwork and plenums to minimize accumulation of dirt and moisture and provide access areas in key locations for inspection, maintenance, and cleaning. Use mastic to seal metal ductwork. Do not substitute rigid fiberglass or flex ductwork. Where possible, locate ductwork in conditioned or semi-conditioned spaces.
- i. Specify duct leakage tests.
- j. Make sure that air handling units and filters are easy to access and maintain.
- k. Reduce duct pressures to minimize the amount of fan energy used to distribute the air. Use low-velocity coils and filters.
- l. To minimize energy consumption, select fans for the highest operating efficiency at predominant operating conditions, and use lower fan speeds to reduce noise levels. Consider direct-drive fans for their improved efficiency. Consider plenum pressurization tracking.
- m. Use filters that meet a minimum of 60% ASHRAE Dust Spot Method Standards.
- n. Consider variable air volume air handling units with variable frequency drives for fans.

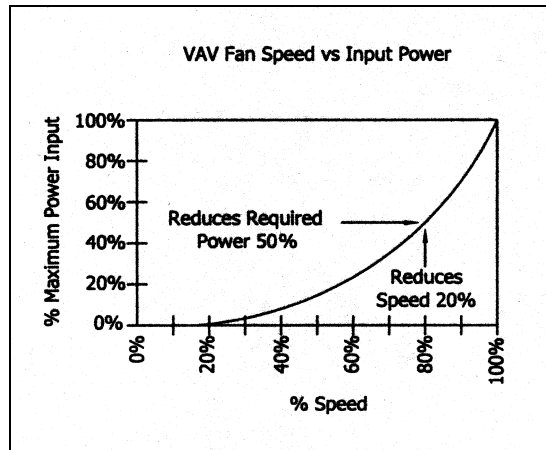

Variable Frequency Drives (VFD) installed on fan motors save considerable amount of power input to the motors.

7. Controls

- a. To ensure proper, energy-efficient operation, implement a control strategy that is tied to key energy systems. Include system optimization, dynamic system control, integrated lighting, and HVAC control.

Note: The size and complexity of the facility must be considered when determining the level of controls and the control system strategy.

- b. Use direct digital control systems for greater accuracy, performance, and energy savings.

Note: The size and complexity of the facility must determine whether a DDC system is warranted.

- c. Set up the HVAC control system to operate according to need. Limit electrical demand during peak hours by turning off (or rotating) non-essential equipment.
- d. Install occupancy or CO₂ sensors to reduce ventilation air requirements for unoccupied spaces and also to switch off lighting in the spaces.
- e. Install sensors for relative humidity and temperature as close to occupants as possible. Consider carbon dioxide concentration sensors which may be a helpful in addition to a properly designed and maintained ventilation system.
- f. Specify VAV controls to ensure that the proper amount of outdoor air is maintained, even when the total supply air is decreased.

- g. Ensure that building management control systems include the functions of:
 - 1. comfort controls;
 - 2. scheduled operation (time-of-use, holiday & seasonal variations);
 - 3. sequence mode-of-operation (optimum start-up);
 - 4. alarms and system reporting;
 - 5. lighting and daylighting integration (including the elimination of at least the final stage of lighting during peak load conditions);
 - 6. maintenance management;
 - 7. indoor air quality reporting (and control of the increase in outdoor air if quality is low);
 - 8. remote monitoring and adjustment potential; and
 - 9. commissioning flexibility.
 - 10. consider Plenum Pressurization Tracking with VAV systems to ensure that the proper amount of outdoor air is maintained.
 - h. At a minimum, the building management system should be programmed to:
 - 1. maximize use of economizer cycles;
 - 2. minimize operating time of all mechanical, electrical and solar systems;
 - 3. control programmed start and stop times;
 - 4. control chilled and hot water temperatures;
 - 5. control and if necessary override lights in daylit spaces to ensure lights are out during times of adequate natural light and simultaneous peak electrical conditions;
 - 6. control general outdoor and interior lighting; and
 - 7. control indoor air quality through the use of pollutant sensors.
 - i. Integrate engineering design strategies to maximize daylighting and integrate with artificial lighting and HVAC controls, to minimize HVAC load (particularly peak load).
 - j. Control strategies for chilled water plant operation should address:
 - 1. variable speed drives;
 - 2. selection of modular chillers or chillers with multiple compressors;
 - 3. chilled water reset;
 - 4. variable flow through chiller;
 - 5. condenser water reset;
 - 6. chiller sequencing;
 - 7. soft-starting of chiller motor; and
 - 8. demand control.
 - k. In smaller facilities, consider time clocks with night and weekend set-backs.
 - l. Coordinate with the owner to establish a means to commission and document the performance of the building management control system and provide training of future maintenance staff.
- 8. Hot and Chilled Water Distribution**
- a. Consider primary pumping systems with variable-speed drives because of their effects on a part-load energy use.
 - b. Prepare piping distribution system layout and pipe sizes to minimize friction losses and save pump energy. Minimize piping bends.
 - c. It may be advantageous to use one pipe size larger than those typically selected, in conjunction with a higher ΔT to reduce power input to pumps. In hot water systems, design for higher ΔT to enable a linear relationship between flow (GPM) and heat transfer and to also allow a linear relationship for heating hot water control valves.

Chilled Water Pump (1000 Ton)

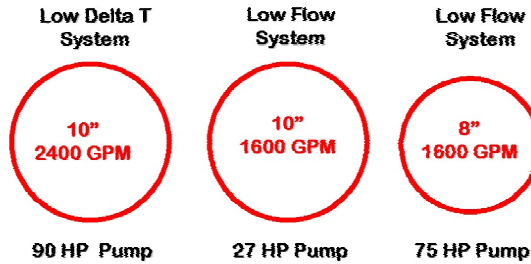

Higher ΔT with a low-flow chilled water system, coupled with a larger pipe size, results in a considerable reduction of power input to the motor for pump.

- d. Carefully select heat exchangers with a low approach temperature and reduced pressure drops.
- e. In large systems with multiple heat exchangers, designate a separate pump for each heat exchanger to maintain high efficiency at part-load operating conditions.
- f. Evaluate type of pumps and pumping arrangement.
- g. Consider variable flow pumping with variable frequency drives for pumps.

9. Heat Recovery and Waste Heat Systems

- a. Significant energy savings can be achieved through the re-capture of waste heat. Outdoor air can be pre-heated in the winter and pre-cooled in the summer by the exhaust air, using heat exchangers between the outdoor and exhaust air streams. To provide exchangers to transfer sensible heat only may be less costly than for both sensible and latent heat. However, both applications should be evaluated.
- b. The use of waste heat or energy rejected at one level can be used for another process. Waste heat is available from many processes rejected heat of compression, refrigeration units, building exhaust air, heat from lights, hot water drains, and solar energy which has been stored in the building mass. A high degree of integration of systems is required to make maximum use of this energy but there is a very high potential for energy conservation.
- c. It is important not to unnecessarily degrade heat which has been stored for later use. Multiple storage tanks are useful to take maximum advantage of the thermodynamic quality of the stored energy.
- d. An exhaust air heat recovery system is used to reduce energy consumption by capturing the energy that would normally be lost to the exhaust airstream. Coil-to-coil exhaust air heat recovery can be applied to pre-cool and pre-heat outside/ventilation air. During "winter" operation, heat extracted from the exhaust airstream is used to pre-heat the temperature of incoming outside air. Preliminary warming of the outside air reduces the heating load placed on the HVAC equipment and, in turn, reduces energy consumption. Summer operation of the coil-to-coil exhaust air heat recovery is used to pre-cool incoming air and thereby reduces the energy consumption of the cooling equipment.

- e. Enthalpy-Wheel Exhaust Air Energy Recovery
 - 1. The increased outdoor/ventilation air requirement mandated by the building code and prescribed by the current ASHRAE Standard creates the opportunity to use heatwheels to realize significant energy savings. Heat is recovered by passing adjacent supply and exhaust air streams through the wheel in a counter flow arrangement. The exchange medium inside the wheel transfers sensible heat by recovering heat from the hot air stream and releasing it to the cold one. Latent heat transfer occurs as the medium collects moisture from the more humid air stream and releases it, through evaporation, to the drier air stream.

- f. Double Bundle Condenser Heat Recovery
 - 1. The “waste heat” which is normally rejected to the cooling tower from the chiller’s cooling condenser bundle is recovered and used to heat - or preheat – domestic hot water and/or for space heating. An example of a typical heat-recovery chiller application is illustrated above. In this instance, the rejected heat is used to satisfy concurrent cooling and heating loads. When a heating load exists, waste heat is recovered by reducing the amount of heat rejected to the cooling tower. This is accomplished by varying water flow to the cooling tower. Depending on the characteristics of the application and the heat-recovery chiller selected, hot water temperatures ranging from 95° F to 120° F can be obtained.